

REALM



MICROOFFICE

Do you work in an office but still want a quiet environment to get your work done? Finding that quiet place is easier than you think! You can find it in a meeting, while tackling a big project or during an informal gathering in our acoustic wellbeing meeting room.



TECHNICAL DETAILS



exterior dimensions	2522 x 2856 x 2285 mm / 99.2 x 112.4 x 90 in
interior dimensions	2245 x 2736 x 2128 mm / 88.4 x 107.7 x 83.8 in
weight	950 kg / 2 094 lb
door dimensions	793 x 2143 mm / 31.2 x 84.4 in
door opening clear dimensions	777 x 2127 mm / 30.6 x 83.7 in
door opens	left
glass doors	sound-insulating glass
glass walls	sound-insulating glass
solid walls	sound-absorbing sandwich panel with acoustic insulation
ceiling	sound-absorbing sandwich panel with acoustic insulation, glazed ceiling
flooring	sound-absorbing sandwich panel with acoustic insulation, carpet (anthracite grey)
glass wall frame and door handle	solid oak wood/black varnish
sound attenuation	speech level reduction $D_{s,a} = 30$ dB (class A) ^{*1}
ventilation	automatic ^{*2} /manual with control panel, air flow 433 m ³ /h ^{*3}
lighting	procognitive, chromaticity temperature 4 800 K
energy consumption	consumption in operation 66 W consumption in standby 1 W
power for MICROOFFICE	220–240 V; 50/60 Hz; 10 A
standard equipment	electric socket (3x), motion sensor, procognitive lighting, ventilation, coat hook (2x), coffee table, shelf (3x), seats, control panel for lighting and air ventilation, glazed ceiling, AV connection points
optional equipment	refer to the pricelist
color options	decorative fabric (refer to swatches)
certification	  ^{*4}

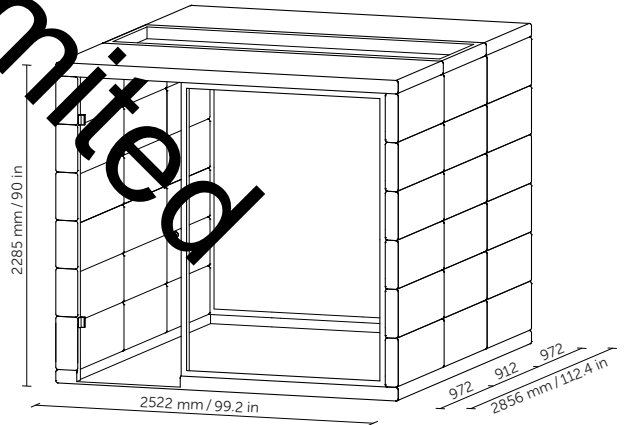

^{*1} ISO 23351-1:2020 – Acoustics — Measurement of speech level reduction of furniture ensembles and enclosures — Part 1: Laboratory method.

^{*2} The fan speed is automatically regulated depending on the temperature difference inside and outside the MICROOFFICE.

^{*3} It is highly recommended to keep at least 15 cm space on the left side where the ventilation inlet is. Please keep also 30 cm above the MICROOFFICE.

^{*4} FSC certification on request.

All intellectual property rights („Rights“), whether registered or not, relating to any content, texts, photographs, images, logos, instructions, designs, technical solutions, etc. („Content“) are the property of SilentLab s.r.o. („Owner“) and any interference with these Rights to any Content or part thereof without the prior express and written consent of the Owner is not permitted.

Any use of the Content not expressly authorized in writing in advance, with the exception of internal and non-commercial use of the unmodified Content for the purposes of the customer's own order, is considered an infringement of the Owner's Rights. In particular (not exclusively), any reproduction, change, addition, merger or other modification of the Content is prohibited without the prior express written consent of the Owner.



ACOUSTICS THAT WORKS

The final product configuration may differ from the versions shown in the photographs. SilentLab®, MICROOFFICE® and their logos are registered trademarks of SilentLab s.r.o. All MICROOFFICE products are patent pending.

version 2023.1